

## DATASHEET

### Multi-Channel Superluminescent Diode Source Integrated Spectral Bench (ISB2)

**Multi-SLED Light Source, 6 SLEDs: 1300nm, 1390nm, 1480nm, 1550nm, 1615nm, 1680nm, PM Fiber, High Degree of Polarization, Spectral Coverage: 1265nm-1725nm, FWHM: 460nm, CW: 1495nm, Light Output Power >40mW**

**DAYY Photonics Part Number: ASM000508**



#DAY-ISB2-1300\_1390\_1480\_1550\_1615\_1680-PM-HP-1265\_1725-460-1495-40\_DS\_2023-01-01

This document is the property of DAYY Photonics, and contains proprietary information. DAYY Photonics reserves the right to make product design or specification changes without notice.

DAYY Photonics Corporation, 4030 8<sup>th</sup> st SW, Calgary, AB Canada, T2G 3A7  
[sales@dayyphotonics.com](mailto:sales@dayyphotonics.com), +1 (587) 328-0739, [www.dayyphotonics.com](http://www.dayyphotonics.com)

## A. PRODUCT DESCRIPTION

The DAYY Photonics broadband multi-superluminescent diode source (Multi-SLED) ASM000508 combines six output beams as a single spectrum product. The system provides individual control of light sources through a digitally controlled interface. Individual SLED performance dashboards are provided for optimum set up calibration as required. The light source is integrated with a high-performance SLED driver and temperature control electronics in a rugged compact package. Power meters can be added for additional monitoring capability.

DAYY Photonics Spectral Stitching technique of integrating multiple wavelengths into a single broad spectrum is designed for optimum coupling efficiency into a single mode fiber. This brings exceptional flexibility and usability to the sensing marketplace. The Multi-SLED can be spectrally tailored to suit specific application needs and offer excellent back reflection immunity. This provides extremely high stability, making these sources ideal for the applications included below:

## B. KEY FEATURES

- Six superluminescent diodes (SLEDs)
- All SLEDs can be run from 0 – 100% of maximum rating
- Fiber-coupled output power: >40mW
- Bandwidth FWHM > 300nm, @10dB > 330nm
- DAYY Photonics patented technology for spectral stitching provides optimum power and bandwidth
- Multiple communication interfaces: USB and RS-232
- Each SLED comes with a built-in independent monitor photodiode and one common thermoelectric cooler (TEC) for all SLEDs
- Internally optimized for maximum coupling efficiency with PM1550-XP Fiber
- Monolithic integration of a Broadband Dual Stage PMF Isolator (35dB)
- Light output: FC/APC Connector (Optional FC/PC or SMA)
- User friendly GUI and custom API available for test automation

## C. APPLICATIONS

- Optical Component Testing
- Telecom Test Equipment
- Medical Optical Coherence Tomography
- Industrial Optical Coherence Tomography
- Metrology
- Biomedical Imaging Systems
- Optical Sensing
- White Light Interferometry & Chromatic Dispersion
- Research and Development

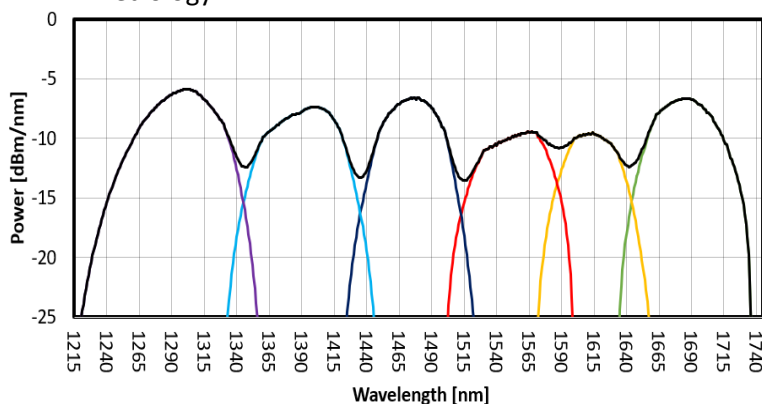

#DAY-ISB2-1300\_1390\_1480\_1550\_1615\_1680-PM-HP-1265\_1725-460-1495-40\_DS\_2023-01-01

This document is the property of DAYY Photonics, and contains proprietary information. DAYY Photonics reserves the right to make product design or specification changes without notice.

**D. ABSOLUTE MAXIMUM RATINGS (see note 1)**

Parameter	Symbol	Condition	Minimum	Maximum	Unit
<b>DRIVER POWER SUPPLY SPECIFICATIONS</b>					
Input Power Supply Voltage	$V_s$	CW	10	14	V
Input Power Supply Current	$I_s$	CW	5	-	A
<b>TEMPERATURE SPECIFICATIONS</b>					
Case Temperature (see note 2)	$T_{Case}$		0	60	°C
Storage Temperature (see note 4)	$T_{stg}$	No condensation, Unbiased	-40	85	°C
Storage Humidity (see note 4)	$RH_{stg}$		5	85	%RH
Ambient Operating Temperature (See note 3)	$T_{Op}$		0	50	°C

**Notes:**

1. Please note that exceeding the Absolute Maximum Ratings above may cause device failure. DAYY Photonics does not bear responsibility for laser power damage that is attributed to electrostatic discharge, excessive current levels, and current spikes (transients). Any attempts to increase the laser drive current above the pre-set limits or recommended specification limits, can damage the device, and nullify the warranty period. It should be emphasized that the current limit set points cannot be exceeded.
2.  $T_{Case}$  and  $T_{TEC}$  are monitored by internal thermistor with external readout.
3. For optimum performance of the Integrated Spectral Bench (ISB2), the ISB2 must be operated within the specified temperature ranges. The Multi-SLED has an internal thermoelectric cooler (TEC) to remove heat from the light source and dissipate it through the ISB2 case. It is required to provide free air circulation around the ISB2 device. It is always recommended to cool down the unit with a fan, and/or to mount the ISB2 on an appropriate heatsink, capable of dissipating up to 15W. The thermal resistance between ISB2 metal case and heatsink can be minimized by applying thermal grease, thermal glue or thermal pad between the contact surfaces. **When the Multi-SLED is used without a heatsink, maximum ambient operating temperature is 35°C.** The specification lists the operating temperature for the electrical/optical characteristics, which is the temperature of the ISB2 during the time that the specifications were measured. Variation in temperature beyond what is specified can have a significant effect on the optical characteristics, like changes in wavelength or drop in output power.
4. Storage temperature and relative humidity should be chosen so the dew point of the humid air around the package is below the storage temperature of the package, to avoid condensation inside the ISB2 enclosure.

**E. OPTICAL AND ELECTRICAL SPECIFICATIONS (see note 5)**

Parameter	Symbol	Condition	Minimum	Typical	Maximum	Unit
<b>DRIVER POWER SUPPLY SPECIFICATIONS</b>						
Input Power Supply Voltage	V <sub>s</sub>	CW	10	12	14	V
Input Power Supply Current	I <sub>s</sub>	CW	5	-	-	A
Input Power Supply Voltage Ripple and Noise	γ	CW	-	-	200	mVpp
<b>OPTICAL SPECIFICATIONS</b>						
Center Wavelength (see note 6)						
SLED 1 – 1680nm	CWL	CW T <sub>OP</sub> = 25°C T <sub>TEC</sub> = 21°C I <sub>OP</sub>	1670	1680	1690	nm
SLED 2 – 1615nm			1605	1615	1625	
SLED 3 – 1550nm			1540	1550	1560	
SLED 4 – 1480nm			1470	1480	1490	
SLED 5 – 1390nm			1380	1390	1400	
SLED 6 – 1300nm			1290	1300	1310	
SLED 1+2+3+4+5+6			1485	1495	1505	
PM Fiber Coupled Power (see note 7)						
SLED 1 – 1680nm	P	CW T <sub>OP</sub> = 25°C T <sub>TEC</sub> = 21°C I <sub>OP</sub>	3	7	-	mW
SLED 2 – 1615nm			3	5		
SLED 3 – 1550nm			3	6		
SLED 4 – 1480nm			3	7		
SLED 5 – 1390nm			3	7		
SLED 6 – 1300nm			3	8		
SLED 1+2+3+4+5+6			18	40		
Bandwidth FWHM (see note 8)						
SLED 1 – 1680nm	B <sub>FWHM</sub>	CW T <sub>OP</sub> = 25°C T <sub>TEC</sub> = 21°C I <sub>OP</sub>		55	-	nm
SLED 2 – 1615nm				45		
SLED 3 – 1550nm				60		
SLED 4 – 1480nm				50		
SLED 5 – 1390nm				65		
SLED 6 – 1300nm				60		
SLED 1+2+3+4+5+6				460		
Bandwidth @ -10dB						
SLED 1 – 1680nm	B <sub>@10dB</sub>	CW T <sub>OP</sub> = 25°C T <sub>TEC</sub> = 21°C I <sub>OP</sub>		90	-	nm
SLED 2 – 1615nm				75		
SLED 3 – 1550nm				85		
SLED 4 – 1480nm				80		
SLED 5 – 1390nm				95		
SLED 6 – 1300nm				90		
SLED 1+2+3+4+5+6				490		
Spectrum Ripple (see note 9)	R	CW T <sub>OP</sub> = 25°C T <sub>TEC</sub> = 21°C I <sub>OP</sub>	< 0.15	< 0.30	< 0.45	dB

#DAY-USB2-1300\_1390\_1480\_1550\_1615\_1680-PM-HP-1265\_1725-460-1495-40\_DS\_2023-01-01

This document is the property of DAYY Photonics, and contains proprietary information. DAYY Photonics reserves the right to make product design or specification changes without notice.

Parameter	Symbol	Condition	Minimum	Typical	Maximum	Unit
Spectral Coverage	SC	CW T <sub>OP</sub> = 25°C T <sub>TEC</sub> = 21°C I <sub>OP</sub>	-	1265 – 1465	-	nm
Polarization Extinction Ratio (see note 10)	PER	CW T <sub>OP</sub> = 25°C T <sub>TEC</sub> = 21°C I <sub>OP</sub>	20.3	-	-	dB
SLED 1 – 1680nm			18.2			
SLED 2 – 1615nm			19.0			
SLED 3 – 1550nm			20.1			
SLED 4 – 1480nm			17.8			
SLED 5 – 1390nm			17.8			
SLED 6 – 1300nm						
RIN	RIN	CW T <sub>OP</sub> = 25°C T <sub>TEC</sub> = 21°C I <sub>OP</sub>	-	< -130	-	dB/Hz
Power Stability (After 1h warm up)	P <sub>STAB</sub>	T <sub>OP</sub> = 25°C ± 2.5	-	< 0.1	-	dB
Warmup Time	W	CW T <sub>OP</sub> = 25°C T <sub>TEC</sub> = 21°C I <sub>OP</sub>	15	30	60	Min.
<b>CONSTANT CURRENT MODE</b>						
Operating Current	I <sub>OP</sub>	CW T <sub>OP</sub> = 25°C T <sub>TEC</sub> = 21°C I <sub>OP</sub>			400	mA
SLED 1 – 1680nm					300	
SLED 2 – 1615nm					500	
SLED 3 – 1550nm					350	
SLED 4 – 1480nm					400	
SLED 5 – 1390nm					500	
SLED 6 – 1300nm						
Current Setting Resolution	R <sub>IOP_SET</sub>				0.1	mA
SLED Current Reading Resolution	R <sub>IOP_READ</sub>			0.1		mA
<b>MODULATION MODE</b>						
Waveform			-	Square	-	
Modulation Frequency Range	f <sub>mod</sub>		0.016	-	1000	Hz
Duty Cycle	D		10	50	90	%
<b>INTERNAL MONITOR DIODE</b>						
Monitor Diode Current Reading	I <sub>mon</sub>		-	-	500	uA
Monitor Diode Current Reading Resolution	RES <sub>Imon</sub>		-	7.6	-	nA
<b>LIGHT OUTPUT CONNECTOR</b>						
Type of Fiber Connector			-	FC/PC, FC/APC, SMA	-	

Parameter	Symbol	Condition	Minimum	Typical	Maximum	Unit
<b>SLED TEC SPECIFICATIONS</b>						

#DAY-ISB2-1300\_1390\_1480\_1550\_1615\_1680-PM-HP-1265\_1725-460-1495-40\_DS\_2023-01-01

This document is the property of DAYY Photonics, and contains proprietary information. DAYY Photonics reserves the right to make product design or specification changes without notice.

SLED TEC Temperature Setpoint	T <sub>SLED_SET</sub>		0	-	40	°C
SLED TEC Temperature Setpoint Resolution	R <sub>TSLED_SET</sub>		-	0.1	-	°C
SLED TEC Temperature Reading	T <sub>SLED_READ</sub>		-40	-	100	°C
SLED TEC Temperature Reading Resolution	R <sub>TSLED_READ</sub>		-	0.1	-	°C
SLED TEC Temperature Reading Resolution	R <sub>TSLED_READ</sub>		-	0.1	-	°C

**TEMPERATURE SPECIFICATIONS**

Heatsink Temperature Reading Range	T <sub>HS</sub>		-40	-	100	°C
Heatsink Temperature Reading Resolution	R <sub>THS</sub>		-	0.1	-	°C
SLED 6 Temperature Reading	R <sub>THS6</sub>		-40		75	°C

Notes:

5. *There may be differences in typical values of output power, power stability, wavelength and bandwidth, due to coupling efficiency. These values are references and there is no guarantee that each particular ISB2 module will have EXACTLY the typical values shown on the previous chart.*
6. *Center Wavelength is defined as the center point of the 3dB bandwidth of each individual SLED.*
7. *The ISB2 – Integrated Spectral Bench uses a Dual Stage Isolator for back reflection protection. Isolators are used to protect a source from back reflections or signals that may occur after the isolator. Back reflections can damage a laser source or cause it to amplitude modulate, or frequency shift. In high-power applications, back reflections can cause instabilities and power spikes. DAYY Photonics does not bear responsibility for laser power damage that is attributed to hot spots in the beam.*
8. *Multi-SLED FWHM is defined as the bandwidth from the lowest spectral dip, when all the SLEDs are on.*
9. *Resolution of 0.1nm. Figure of merit does not include dips between SLEDs.*
10. *Polarization Extinction Ratio is defined as the ratio of optical powers of perpendicular polarizations, expressed in decibels (dB).*

**F. PLOTS - Test performed at T<sub>OP</sub>=25°C and T<sub>TEC</sub>=21°C**

#DAY-ISB2-1300\_1390\_1480\_1550\_1615\_1680-PM-HP-1265\_1725-460-1495-40\_DS\_2023-01-01

This document is the property of DAYY Photonics, and contains proprietary information. DAYY Photonics reserves the right to make product design or specification changes without notice.

**FIG. 1: ISB2 SPECTRUM**

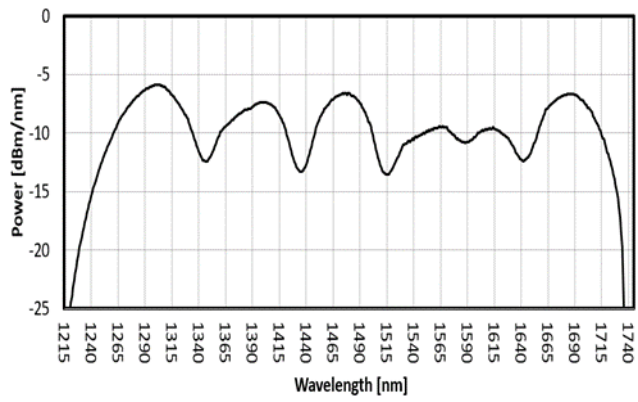

**FIG. 2: SLED 1 SPECTRUM**

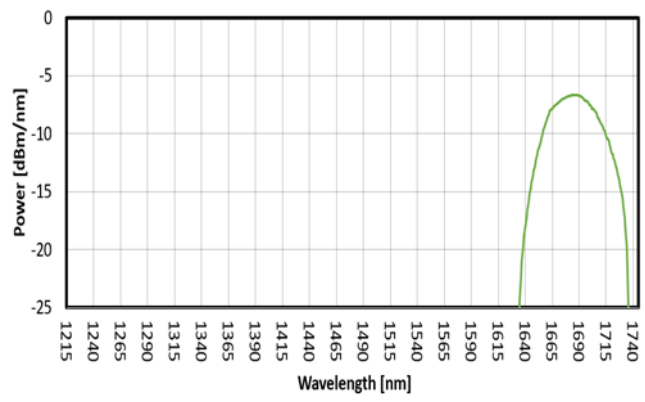

**FIG. 3: SLED 2 SPECTRUM**

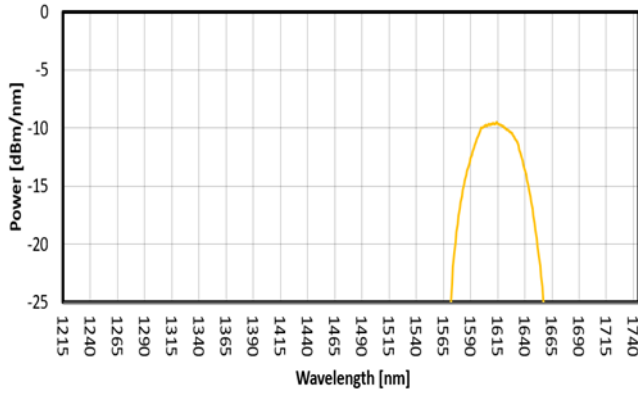

**FIG. 4: SLED 3 SPECTRUM**

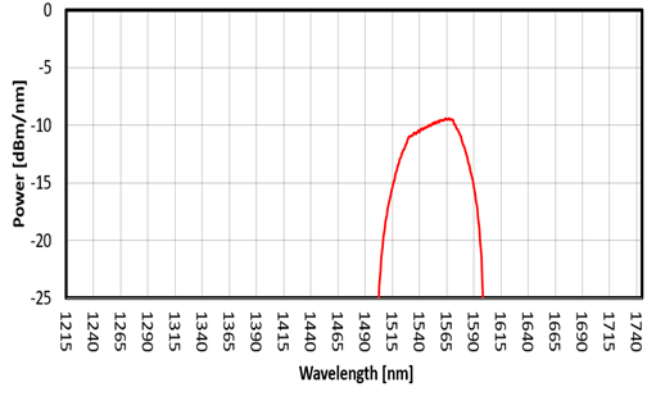

**FIG. 5: SLED 4 SPECTRUM**

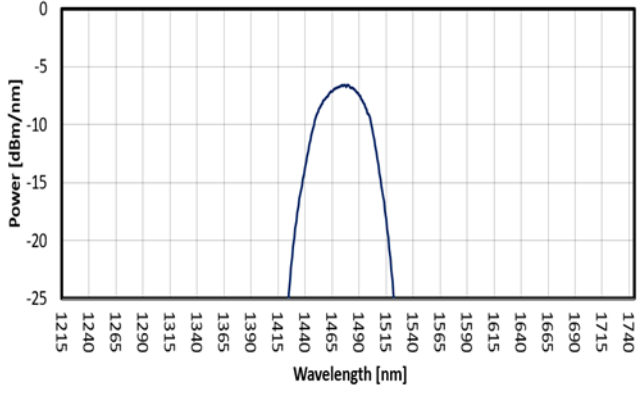

**FIG. 6: SLED 5 SPECTRUM**

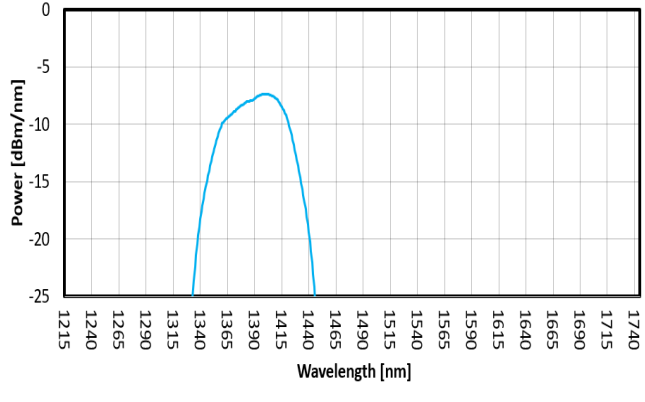

#DAY-ISB2-1300\_1390\_1480\_1550\_1615\_1680-PM-HP-1265\_1725-460-1495-40\_DS\_2023-01-01

This document is the property of DAYY Photonics, and contains proprietary information. DAYY Photonics reserves the right to make product design or specification changes without notice.

**FIG. 7: SLED 6 SPECTRUM**

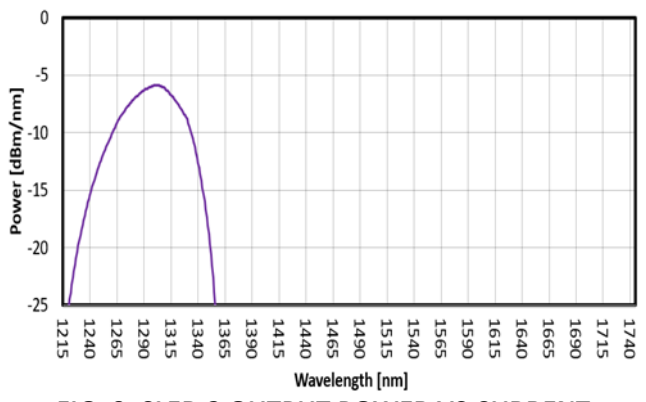

**FIG. 8: SLED 1 OUTPUT POWER VS CURRENT**

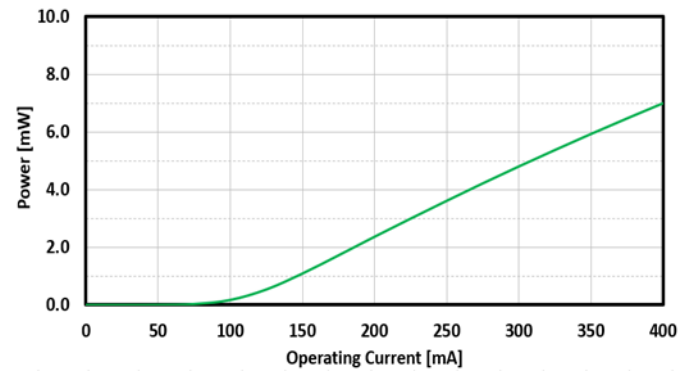

**FIG. 9: SLED 2 OUTPUT POWER VS CURRENT**

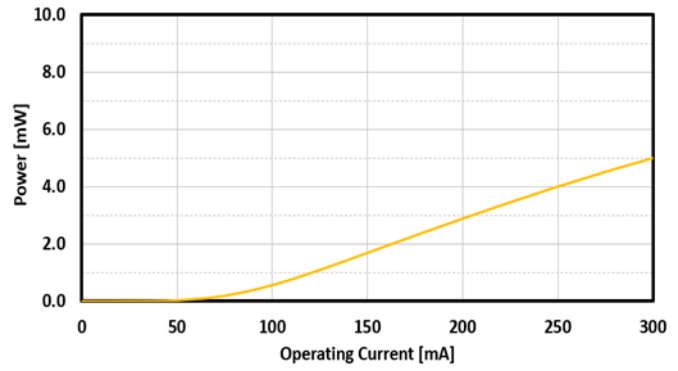

**FIG. 10: SLED 3 OUTPUT POWER VS CURRENT**

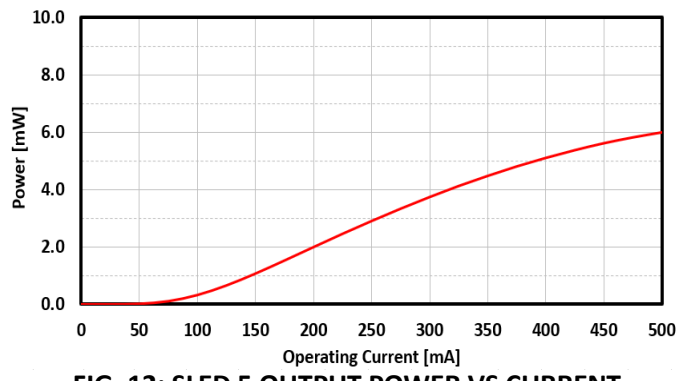

**FIG. 11: SLED 4 OUTPUT POWER VS CURRENT**

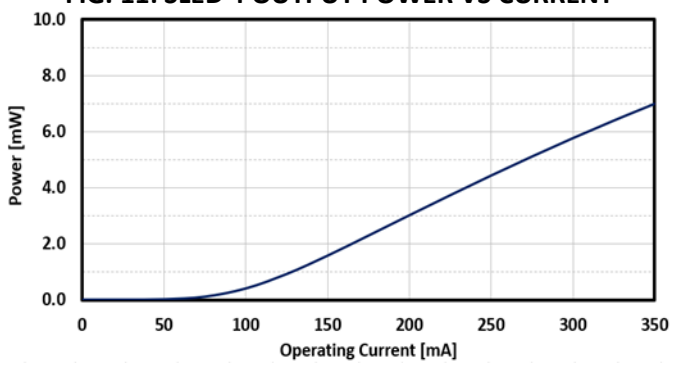

**FIG. 12: SLED 5 OUTPUT POWER VS CURRENT**

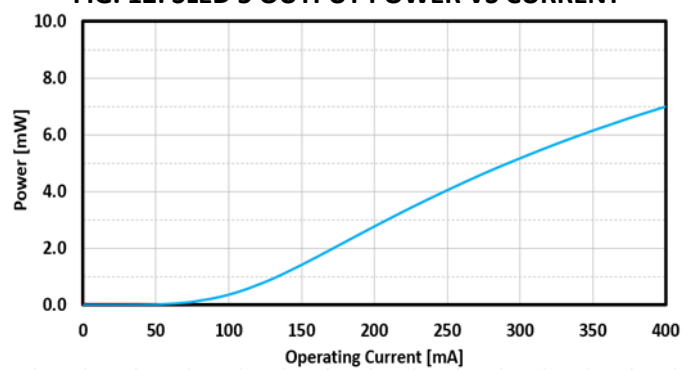

**FIG. 13: SLED 6 OUTPUT POWER VS CURRENT**

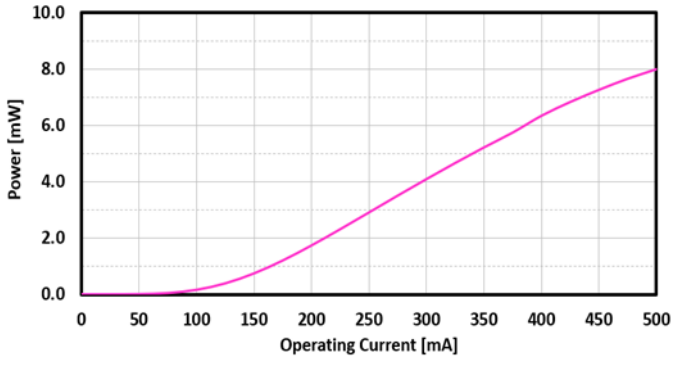

#DAY-ISB2-1300\_1390\_1480\_1550\_1615\_1680-PM-HP-1265\_1725-460-1495-40\_DS\_2023-01-01

This document is the property of DAYY Photonics, and contains proprietary information. DAYY Photonics reserves the right to make product design or specification changes without notice.

FIG. 14: ISB2 TYPICAL POWER STABILITY

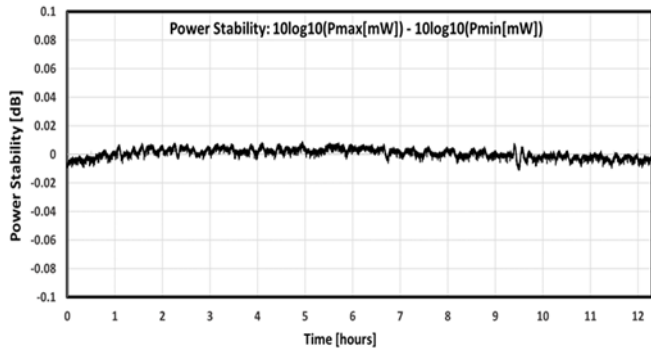
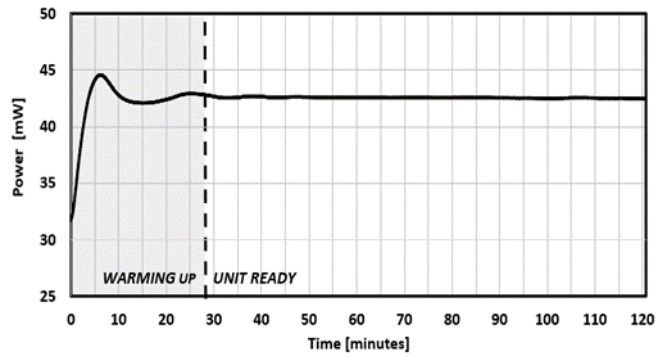

FIG. 15: WARM-UP TIME



G. CONNECTORS



Item	Description
A	FC/APC Connector (Optional: FC/PC, SMA)
B	Power Barrel Connector Jack 2.00mm ID, 5.50mm OD, 9.5 mm Length. Center Positive $\ominus$ — $\oplus$ Input: AC 100-240V Output: 12V 5V min
C	USB 2.0 Type B
D	RJ45 for MODBUS TCP/IP Communication – Being discontinued
E	D-SUB 9 Positions for RS-232 Communication
F	Switches to change between PC Mode - Manual Mode and to turn SLED on when operating in Manual Mode

**H. D-SUB CONNECTOR PIN OUT**

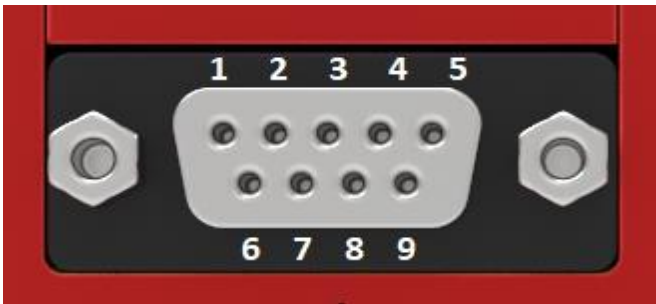

Pin #	Function RS-232
1	Not used
2	Tx
3	Rx
4	Not used
5	GND
6	Not used
7	Not used
8	Not used
9	Not used

**I. MANUAL CONTROL**

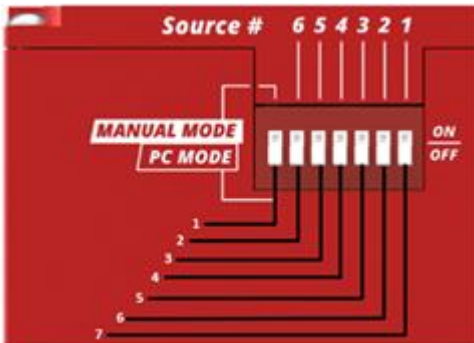

Pin #	UP	DOWN
1	Light Source in Manual Mode	Light Source in PC Mode
2	SLED 6 ON	SLED 6 OFF
3	SLED 5 ON	SLED 5 OFF
4	SLED 4 ON	SLED 4 OFF
5	SLED 3 ON	SLED 3 OFF
6	SLED 2 ON	SLED 2 OFF
7	SLED 1 ON	SLED 1 OFF

J. OSE2 32-PIN BUTTERFLY PACKAGE PIN OUT

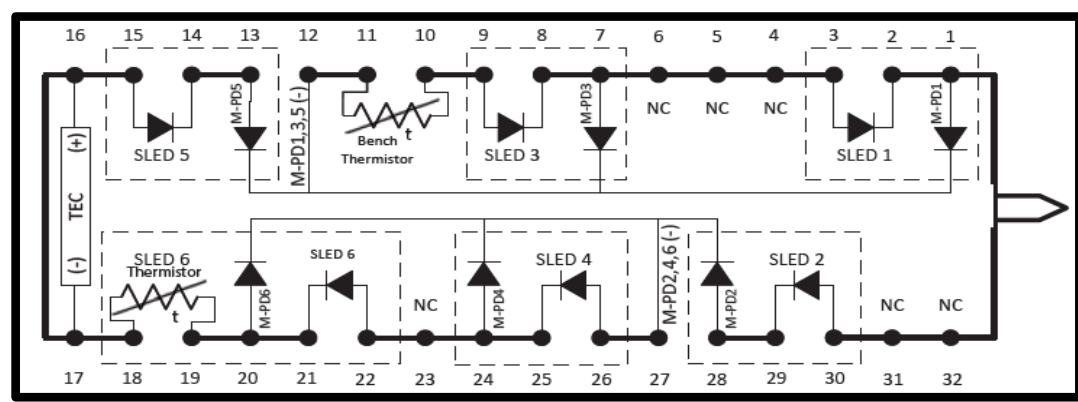

External Pin Assignment – Multi-SLED: 6 SLEDs							
1	M-PD1 (+)	9	SLED 3(+)	17	TEC (-)	25	SLED 4 (-)
2	SLED 1 (-)	10	Thermistor	18	SLED 6 Thermistor	26	SLED 4 (+)
3	SLED 1 (+)	11	Thermistor	19	SLED 6 Thermistor	27	M-PD2,4,6 (-)
4	NC	12	M-PD1,3,5 (-)	20	M-PD6 (+)	28	M-PD2 (+)
5	NC	13	M-PD5 (+)	21	SLED 6 (-)	29	SLED 2 (-)
6	NC	14	SLED 5 (-)	22	SLED 6 (+)	30	SLED 2 (+)
7	M-PD3 (+)	15	SLED 5 (+)	23	NC	31	NC
8	SLED 3 (-)	16	TEC (+)	24	M-PD4 (+)	32	NC

#DAY-ISB2-1300\_1390\_1480\_1550\_1615\_1680-PM-HP-1265\_1725-460-1495-40\_DS\_2023-01-01

This document is the property of DAYY Photonics, and contains proprietary information. DAYY Photonics reserves the right to make product design or specification changes without notice.

**K. MECHANICAL DIAGRAM – ISB2**

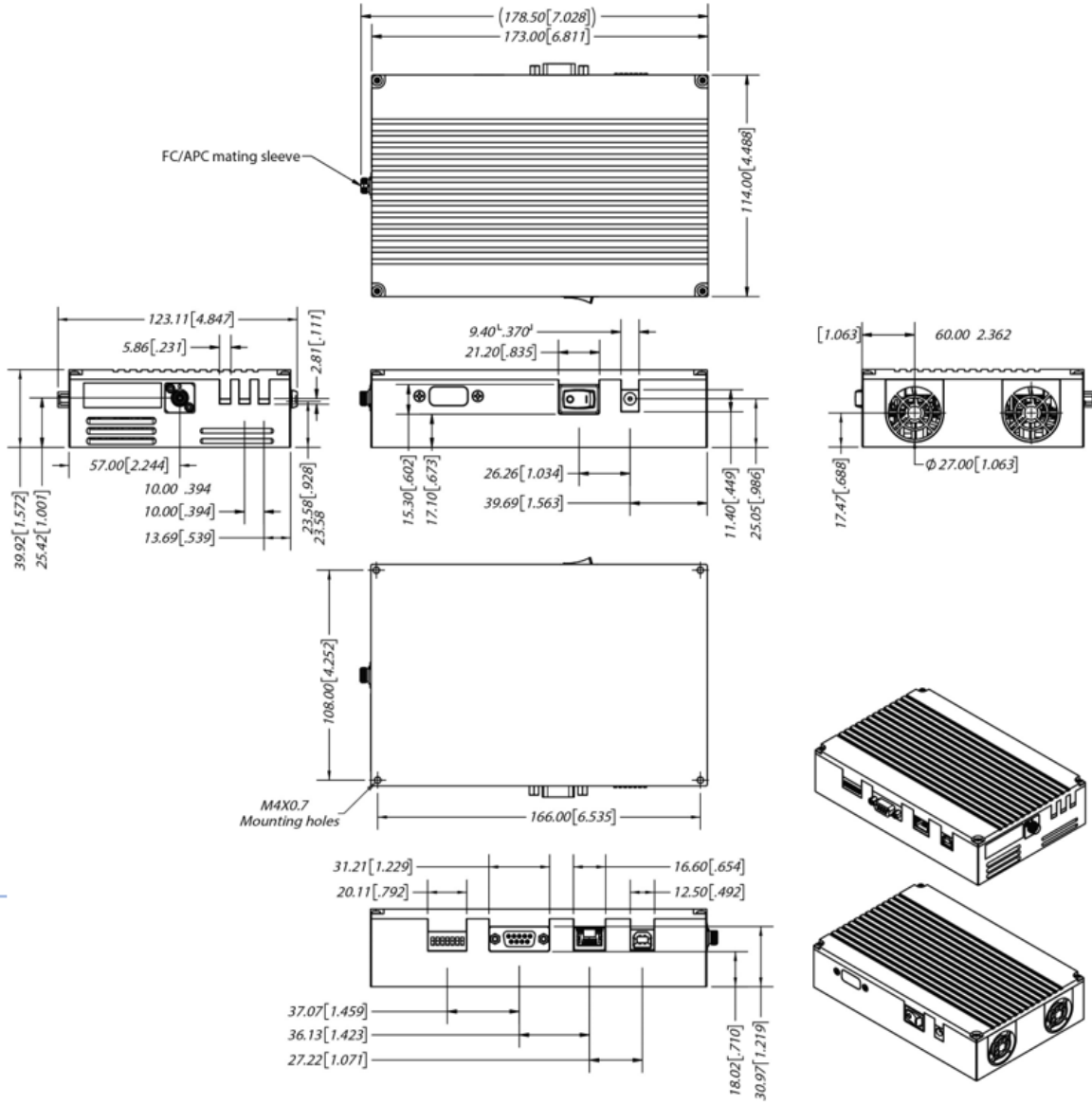

#DAY-ISB2-1300\_1390\_1480\_1550\_1615\_1680-PM-HP-1265\_1725-460-1495-40\_DS\_2023-01-01

This document is the property of DAYY Photonics, and contains proprietary information. DAYY Photonics reserves the right to make product design or specification changes without notice.

**L. SAFETY**

All statements regarding safety of operation and technical data will only apply when the unit is operated correctly.

The driver must not be operated in environments susceptible to explosion hazards. Do not obstruct the air ventilation slots. If any parts of the driver, or electronics are broken or exposed, contact DAYY Photonics technical support and do not attempt to operate the unit.

The Multi-SLED Integrated Spectral Bench (ISB2) is a Class 1M laser product. It is safe for all conditions of use except when passed through magnifying optics such as microscopes and telescopes. It produces a beam that is divergent. If light is re-focused use protective eye wear.

**M. APPLICATION PROTOCOL INTERFACE (API)**

DAYY Photonics driver utilizes the MODBUS Protocol for communications. Users can find numerous detailed specifications for the protocol on the internet. MODBUS is used widely in industrial applications. The driver is designed to use this protocol over all of its communication interfaces, MODBUS – RTU is a master/slave protocol and is employed by the USB or RS232 port.

The MODBUS specification has outlined how a user can adapt the overall packet structure to suit each interface requirement. The primary section of a MODBUS packet is known as the Protocol Data Unit (PDU) and it is independent of the underlying communication interface. The PDU includes additional byte fields for the MODBUS transaction per the Application Data Unit (ADU).

A high-level overview of MODBUS Protocol can be found on the Multi-SLED Integrated Spectral Bench User Manual. If users want to develop their own API, the ISB2 Register Map is available upon request. Please contact technical support: [techsupport@dayyphotonics.com](mailto:techsupport@dayyphotonics.com).